

Product information

Drum motors

TM 315-50



Van der Graaf
Power Transmission Equipment

www.vandergraafpte.nl

The TM 315's



playground



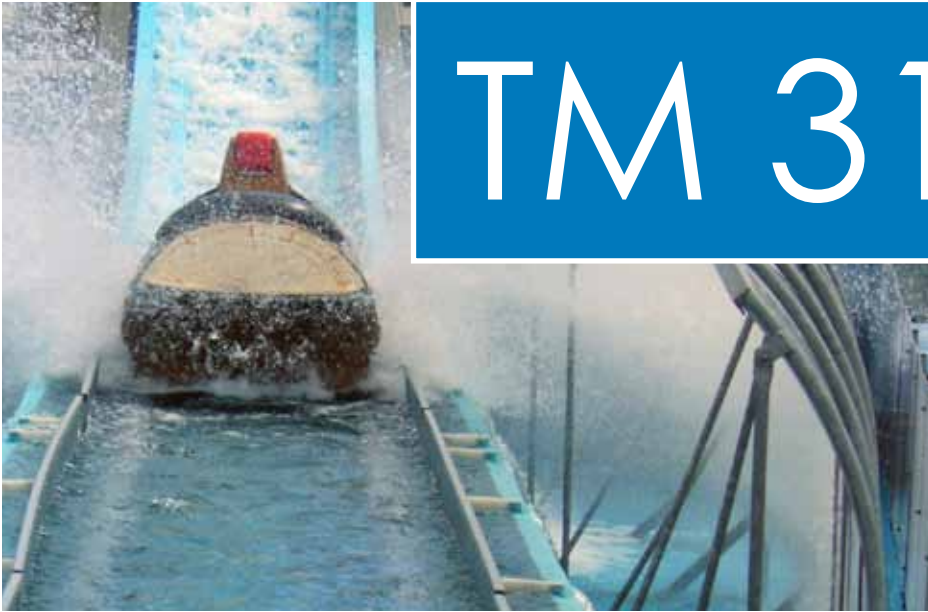

TM 315-50

A wide range of applications

Van der Graaf has achieved a prominent position on both the domestic and international market with its "GV" Drummotors.

The "GV" Drummotor has found success in a wide range of applications including the following: automotive, X-ray, construction, postal, courier, mining, aggregate, airline baggage, package flow, tyre manufacturing, fish processing, poultry processing, meat processing, agriculture, fruit and vegetable, farming, forestry, baking, dairy and many more.

4	Introduction
5	Selection table
6	Selection table Dahlander motors
7	Dimensions Drummotors mild steel
8	Dimensions Drummotors stainless steel
9	Dimensions Taildrums mild steel
10	Dimensions Taildrums stainless steel
11	Dimensions bracket
12	Cable exit
13	Cross sectional / parts description
16	Options
19	Product range
20	Contact us



Selection table

TYPE TM 315.50	Power kW	Beltspeed m/s at 50 Hz								Min. L mm Design A	Min. L mm Design B	Full load curr. 400 V - 50 Hz I = ... A	Weight kg L=600		
		Beltpull N													
215	11,0	4,40	3,80	3,40	3,00						600	650	19,7	178	
215 Z		2375	2750	3075	3485										
215 ZV		2,80	2,50	2,40	2,20	3730	4180	4355	4750						
		1,90	1,60												
		5500	6530												
410	7,5	4,10	3,40	3,00	2,40	2,20	1,90	1,70	1,50		600	650	15,0	178	
410 Z		1740	2095	2375	2970	3240	3750	4190	4750						
410 ZV		1,40	1,25	1,20	1,10	5090	5700	5940	6475						
475	5,5	4,10	3,40	3,00	2,40	2,20	1,90	1,70	1,50		550	600	10,5	173	
475 Z		1275	1535	1740	2175	2375	2750	3075	3485						
475 ZV		1,40	1,25	1,20	1,10	3730	4180	4355	4750						
		0,95	0,80												
		5500	6530												
455	4,0	4,10	3,40	3,00	2,40	2,30	1,90	1,70	1,50	1,40	1,20	500	550	7,8	168
455 Z		925	1120	1265	1585	1650	2000	2235	2535	2715	3165				
455 ZV		1,10	0,90												
		3455	4220												
		0,80													
		4750													
		0,70	0,65	0,60	0,55										
		5430	5845	6335	6910										
440	3,0	2,30	1,90	1,70	1,50	1,40	1,20	1,10	0,90	0,80	500	550	6,6	168	
440 Z		1240	1500	1675	1900	2035	2375	2590	3165	3565					
440 ZV		0,70	0,60												
		4070	4750												
		0,55	0,50												
		5180	5700												
640	3,0	2,70	1,60								500	550	7,1	168	
640 Z		1055	1780												
640 ZV		0,45	0,40												
		6335	7125												
630	2,2	1,50	1,20	1,10	0,90	0,80	0,70	0,60	0,50		500	550	4,9	168	
630 Z		1395	1740	1900	2320	2615	2985	3485	4180						
630 ZV		0,45													
		4645													
		0,40	0,38	0,34											
		5225	5500	6145											
820	1,5	1,10	0,90	0,85	0,65	0,60	0,55	0,45	0,40		500	550	4,6	168	
820 Z		1295	1585	1675	2190	2375	2590	3165	3565						
820 ZV		0,37	0,32	0,29											
		3850	4455	4915											
		0,25													
		5700													
1220	1,5	0,70	0,35								550	600	5,8	173	
1220 Z		2035	4070												
1220 ZV		0,24	0,21												
		5940	6785												
815	1,1	1,10	0,90	0,85	0,65	0,60	0,55	0,45	0,40		500	550	3,3	168	
815 Z		950	1160	1230	1610	1740	1900	2320	2615						
815 ZV		0,37	0,32	0,29	0,25										
		2825	3265	3605	4180										
1215	1,1	0,70	0,35								500	550	5,9	168	
1215 Z		1495	2985												
1215 ZV		0,24													
		4355													
		0,19	0,16												
		5500	6530												

Available standard facewidth's: 500 - 550 - 600 - 650 - 700 - 750 - 800 - 850 - 900 - 950 - 1000 - 1050 - 1100 - 1150 mm

When an electro-mechanical brake is fitted, the minimum facewidth is increased by 150 mm

When a backstop is fitted in a 2-pole drum motor, the minimum facewidth is increased by 50 mm

The total weight of a Drummotor grows approx. 7 kg per 100 mm

Available torque: (Beltpull N x drum diameter m) / 2 Nm

Selection table Dahlander motors

TYPE TM 315.50	Power kW	Beltspeed m/s at 50 Hz					Min. L mm Design A	Min. L mm Design B	Full load curr. 400 V - 50 Hz I = ... A	Weight kg L=600			
		Beltpull N											
470/210 470/210 Z 470/210 ZV	5,0/7,5	2,40/4,80 1980/1485 1,30/2,60 3655/2740 0,95/1,90 5000/3750	2,20/4,40 2160/1620 1,25/2,50 3800/2850 0,80/1,60 5940/4455	1,90/3,80 2500/1875 1,20/2,40 3960/2970	1,70/3,40 2795/2095 1,10/2,20 4320/3240	1,50/3,00 3165/2375	600	650	10,6/15,2	178			
455/275 455/275 Z 455/275 ZV	4,0/5,5	2,40/4,80 1585/1090 1,10/2,20 3455/2375 0,80/1,60 4750/3265	2,20/4,40 1725/1190 0,90/1,80 4220/2905	1,90/3,80 2000/1375	1,80/3,60 2110/1450	1,70/3,40 2235/1535	1,50/3,00 2535/1740	1,40/2,80 2715/1865	1,20/2,40 3165/2175	550	600	7,8/10,9	173
440/255 440/255 Z 440/255 ZV	3,0/4,0	2,20/4,40 1295/865 0,80/1,60 3565/2375	1,80/3,60 1585/1055	1,70/3,40 1675/1120	1,50/3,00 1900/1265	1,40/2,80 2035/1355	1,20/2,40 2375/1585	1,10/2,20 2590/1725	0,90/1,80 3165/2110	500	550	5,8/7,1	168
830/440 830/440 ZV	2,2/3,0	1,10/2,20 1900/1295 0,40/0,80 5225/3565	0,90/1,80 2320/1585 0,35/0,70 5970/4070	0,85/1,70 2460/1675 0,32/0,64 6530/4455	0,75/1,50 2785/1900 0,30/0,60 6965/4750	0,70/1,40 2985/2035	0,60/1,20 3485/2375	0,55/1,10 3800/2590	0,45/0,90 4645/3165	550	600	7,7/5,9	173
820/430 820/430 Z 820/430 ZV	1,5/2,2	2,05/4,10 695/510 0,70/1,40 2035/1495 0,35/0,70 4070/2985 0,28/0,55 5180/3800	1,70/3,40 840/615 0,60/1,20 2375/1740 0,32/0,64 4455/3265 0,25/0,50 5700/4180	1,50/3,00 950/695 0,55/1,10 2590/1900 0,30/0,60 4750/3485	1,20/2,40 1190/870 0,45/0,90 3165/2320	1,10/2,20 1295/950	0,90/1,80 1585/1160	0,85/1,70 1675/1230	0,75/1,50 1900/1395	500	550	5,8/4,7	168

Available standard facewidth's: 500 - 550 - 600 - 650 - 700 - 750 - 800 - 850 - 900 - 950 - 1000 - 1050 - 1100 - 1150 mm

When an electro-mechanical brake is fitted, the minimum facewidth is increased by 150 mm

When a backstop is fitted in a 2-pole drum motor, the minimum facewidth is increased by 50 mm

The total weight of a Drummotor grows approx. 7 kg per 100 mm

Available torque: (Beltpull N x drum diameter m) / 2 Nm

Dimensions Drummotors stainless steel

TM 315A50 CR

TM 315A50 CR, stainless steel Drummotor with polyamide junctionbox and CR sealing

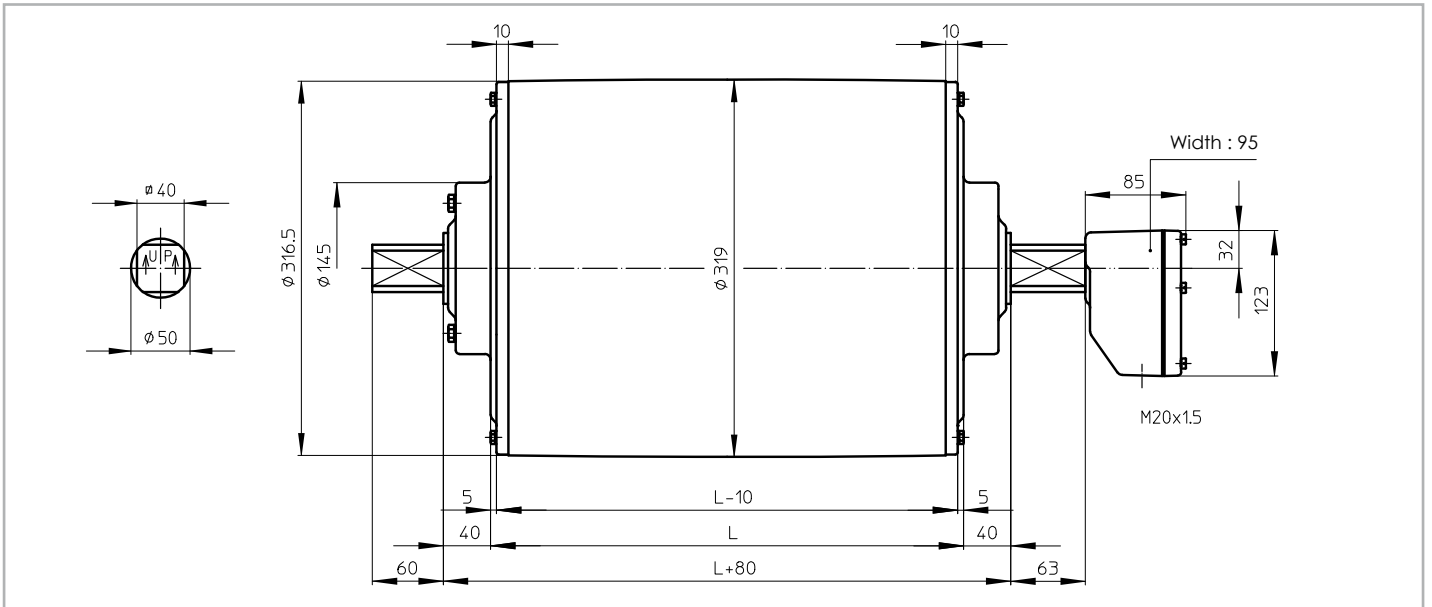

TM 315B50 CR

TM 315B50 CR, stainless steel Drummotor with polyamide junctionbox and CR sealing

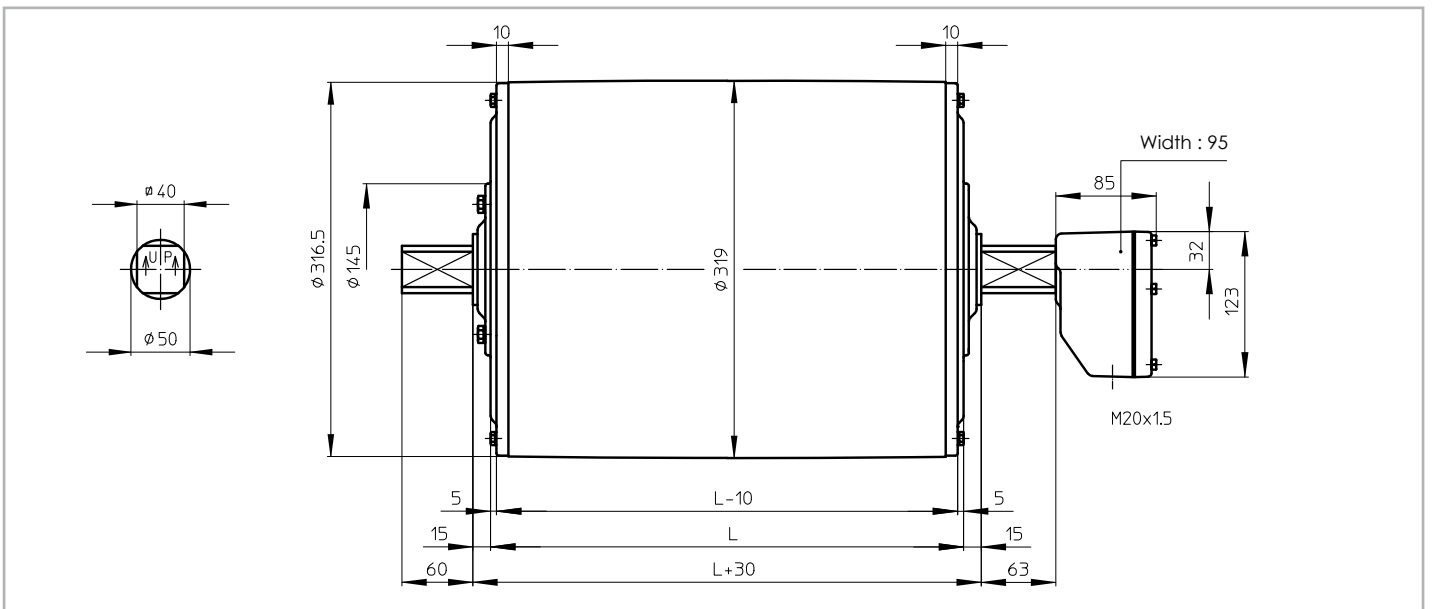



Dimensions Taildrums mild steel

KT 315A50

KT 315A50, mild steel Taildrum

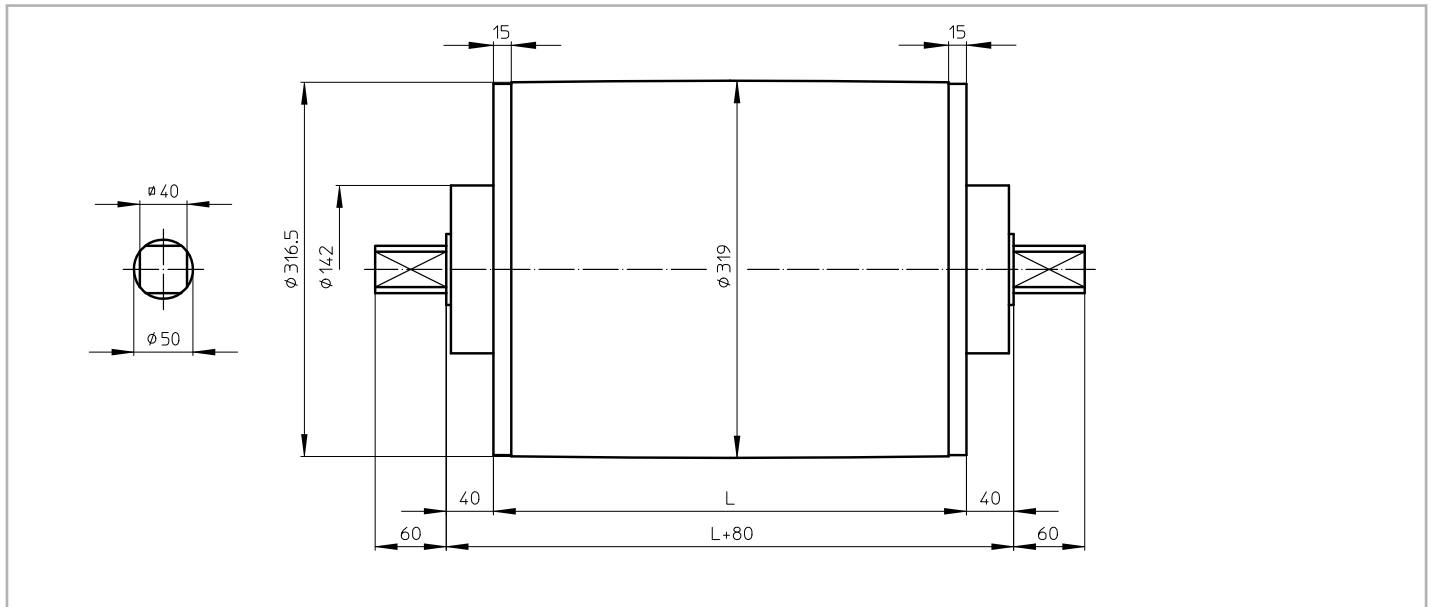

KT 315B50

KT 315B50, mild steel Taildrum

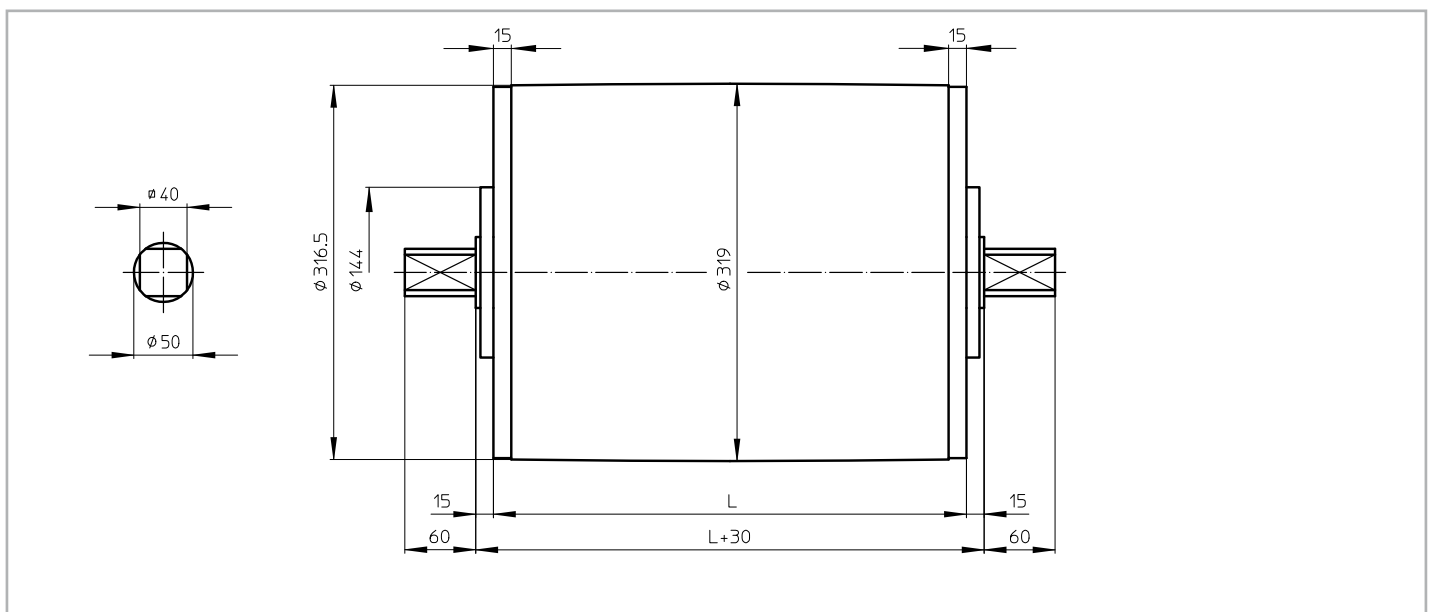

Dimensions Taildrums stainless steel

KT 315A50 CR

KT 315A50 CR, stainless steel Taildrum with CR sealing

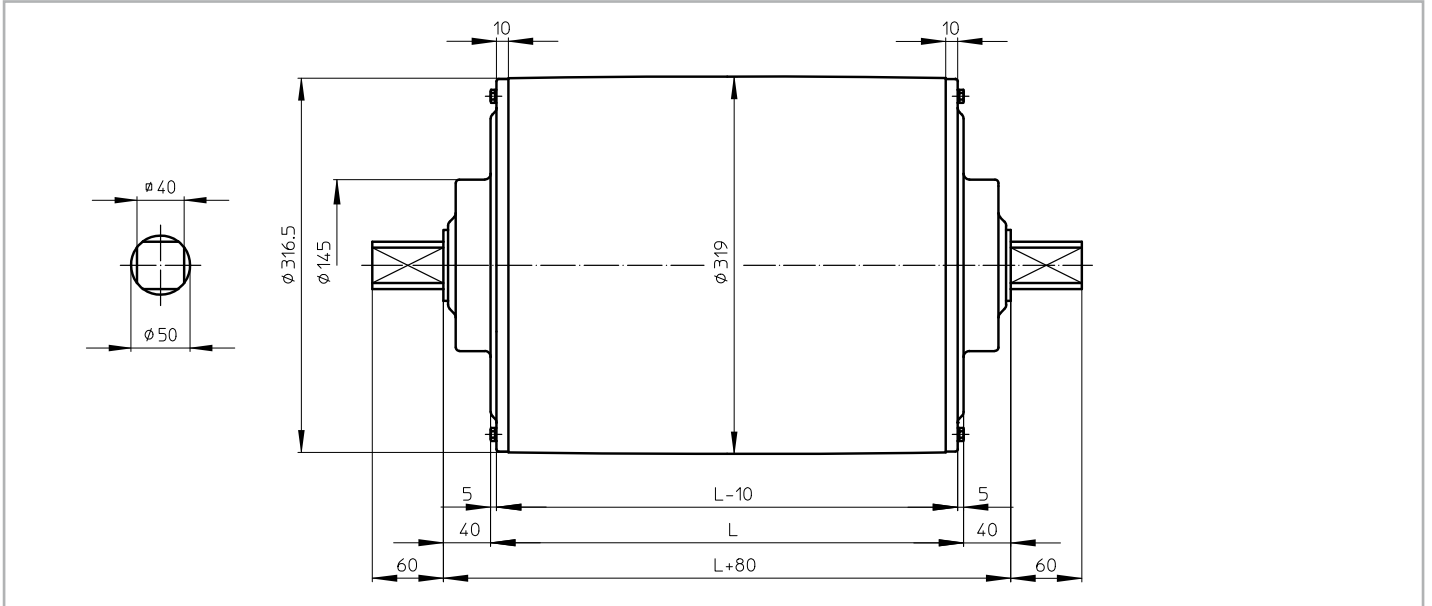

KT 315B50 CR

KT 315B50 CR, stainless steel Taildrum with CR sealing

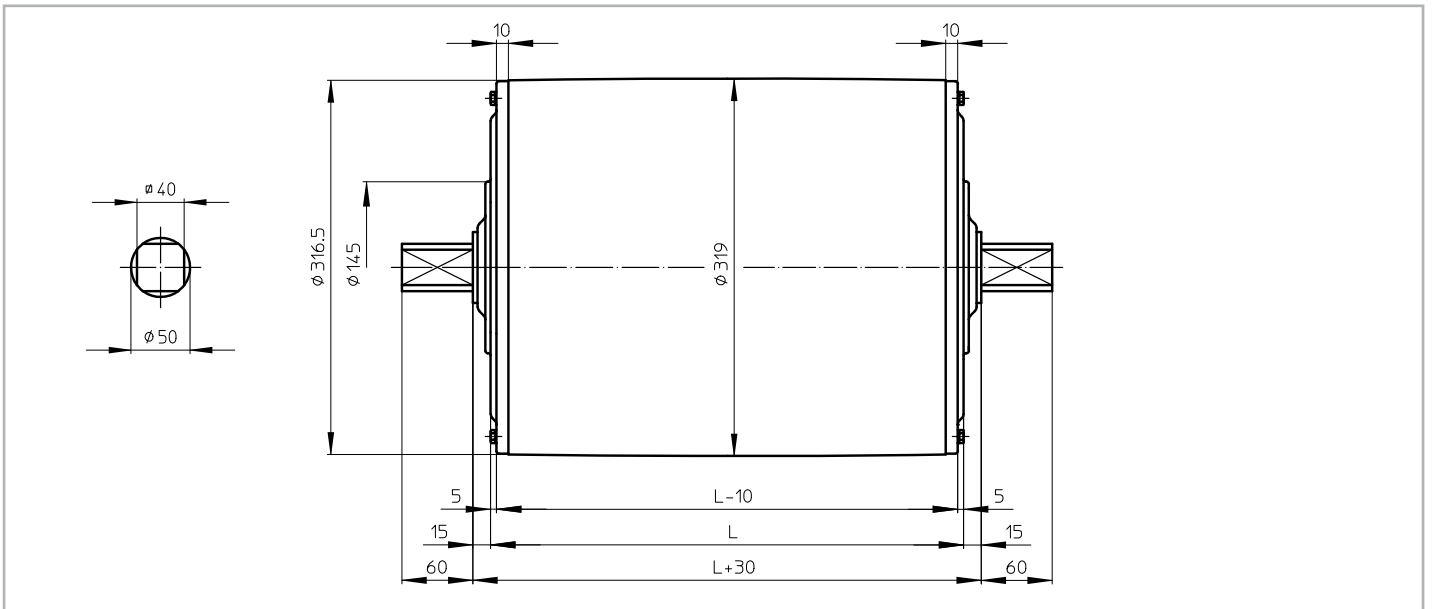



Dimensions bracket

AB 50

AB 50, cast iron or stainless steel bracket
Weight: 7,2 kg per pair

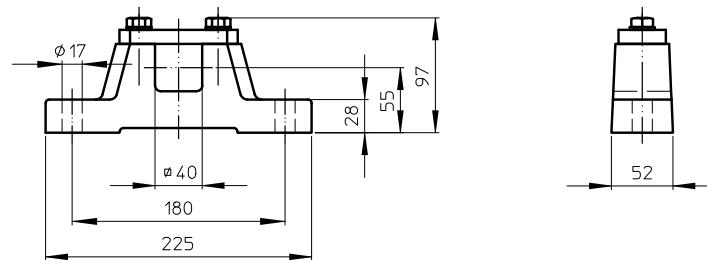

Cable exit

Standard design of a TM 315-50 is with a cast iron junctionbox. For stainless steel design, this can be either a cast iron PU coated cast iron or stainless steel junctionbox.

On request a drum motor can be fitted with a cable. In this case it is important to know the available voltage (preferably 1 voltage), the length of the cable, whether the cable is shielded or not and the type of cable exit.

An overview of available cable exits is shown below.

Option 1

Straight cable exit with cable gland

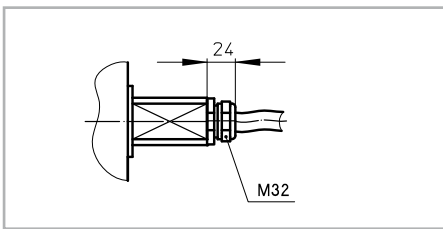

Option 3

Elbow cable exit with cable gland
(minimum facewidth increases with 50 mm)

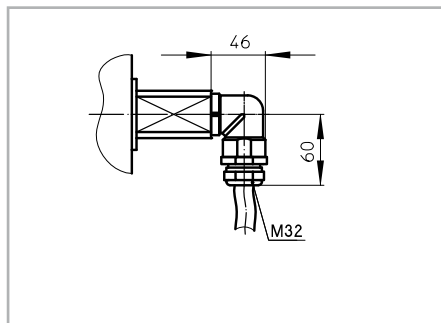



TM 315A50

Legenda

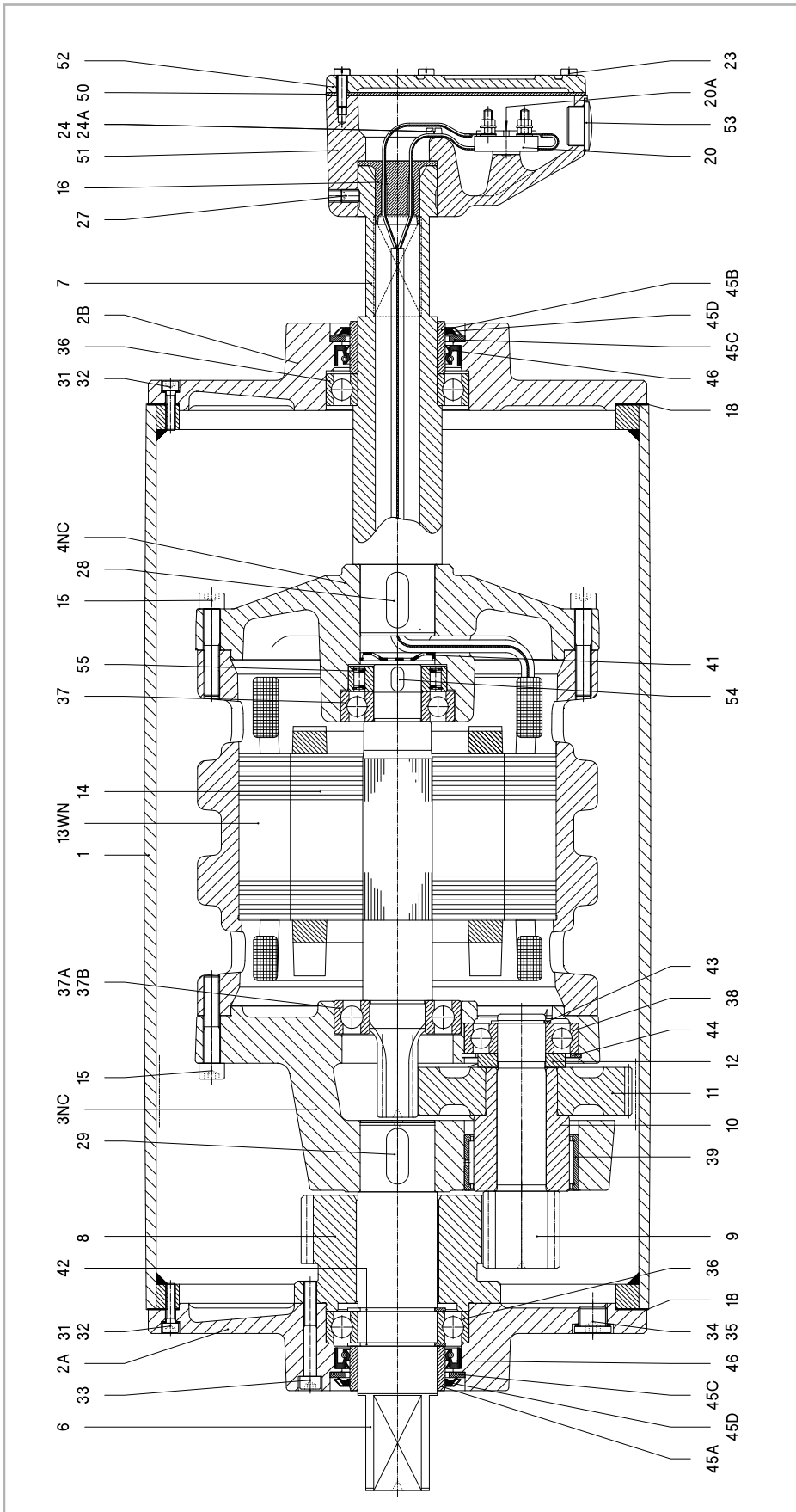

Remark: Drummotor also available in B-design (TM315B50)

1	Shell	13WN	Stator	29	Key	39	Needlebearing	51	Junctionbox
2A	Endflange	14	Rotor	31	Int. hex screw	41	Disc	52	Junctionbox cover
2B	Endflange	15	Int. hex screw	32	Washer	42	Circlip	53	Stopping plug
3NC	Gearhousing	16	Cable passage	33	Int. hex screw	43	Circlip	54	Key
4NC	Motoflange	18	Gasket	34	Fillerplug	44	Circlip	55	Backstop
6	Shaftend	20	Terminalboard	35	Washer	45A	Bearing race	57	Dataplate
7	Hollow shaft	20A	Cyl. head screw	36	Ballbearing	45B	Bearing race		
8	External gear	23	Cyl. head screw	37	Ballbearing	45C	Shim plated		
9/10	Pinion with bush	24	Cyl. head screw	37A	Ballbearing	45D	Gammaring		
11	Gear	24A	Toothed lock washer	37B	Ballbearing	46	Olised		
12	Distance ring	27	Setscrew	38	Ballbearing	50	Seal		

Cross sectional / parts description

TM 315A50 Z

Legenda

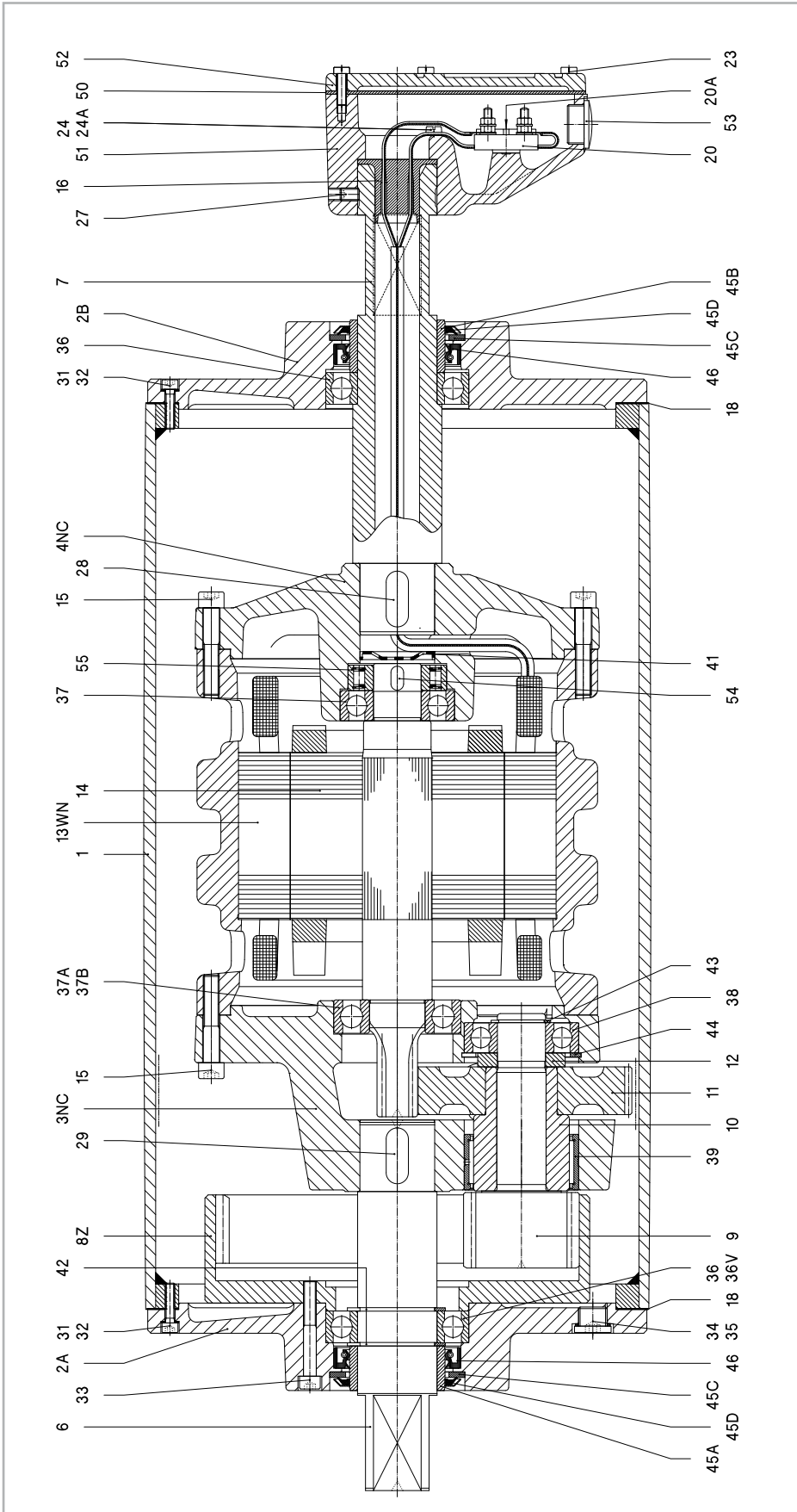

Remark: Drummotor also available in B-design (TM315B50 Z)

1	Shell	13WN	Stator	29	Key	38	Ballbearing	50	Seal
2A	Endflange	14	Rotor	31	Int. hex screw	39	Needlebearing	51	Junctionbox
2B	Endflange	15	Int. hex screw	32	Washer	41	Disc	52	Junctionbox cover
3NC	Gearhousing	16	Cable passage	33	Int. hex screw	42	Circlip	53	Stopping plug
4NC	Motoflange	18	Gasket	34	Fillerplug	43	Circlip	54	Key
6	Shaftend	20	Terminalboard	35	Washer	44	Circlip	55	Backstop
7	Hollow shaft	20A	Cyl. head screw	36	Ballbearing	45A	Bearing race	57	Dataplate
8Z	Internal gear	23	Cyl. head screw	36V	Cyl. roller bearing	45B	Bearing race		
9/10	Pinion with bush	24	Cyl. head screw	37	Ballbearing	45C	Shim plated		
11	Gear	24A	Toothed lock washer	37A	Ballbearing	45D	Gammaring		
12	Distance ring	27	Setscrew	37B	Ballbearing	46	Olised		

KT 315A50

Legenda

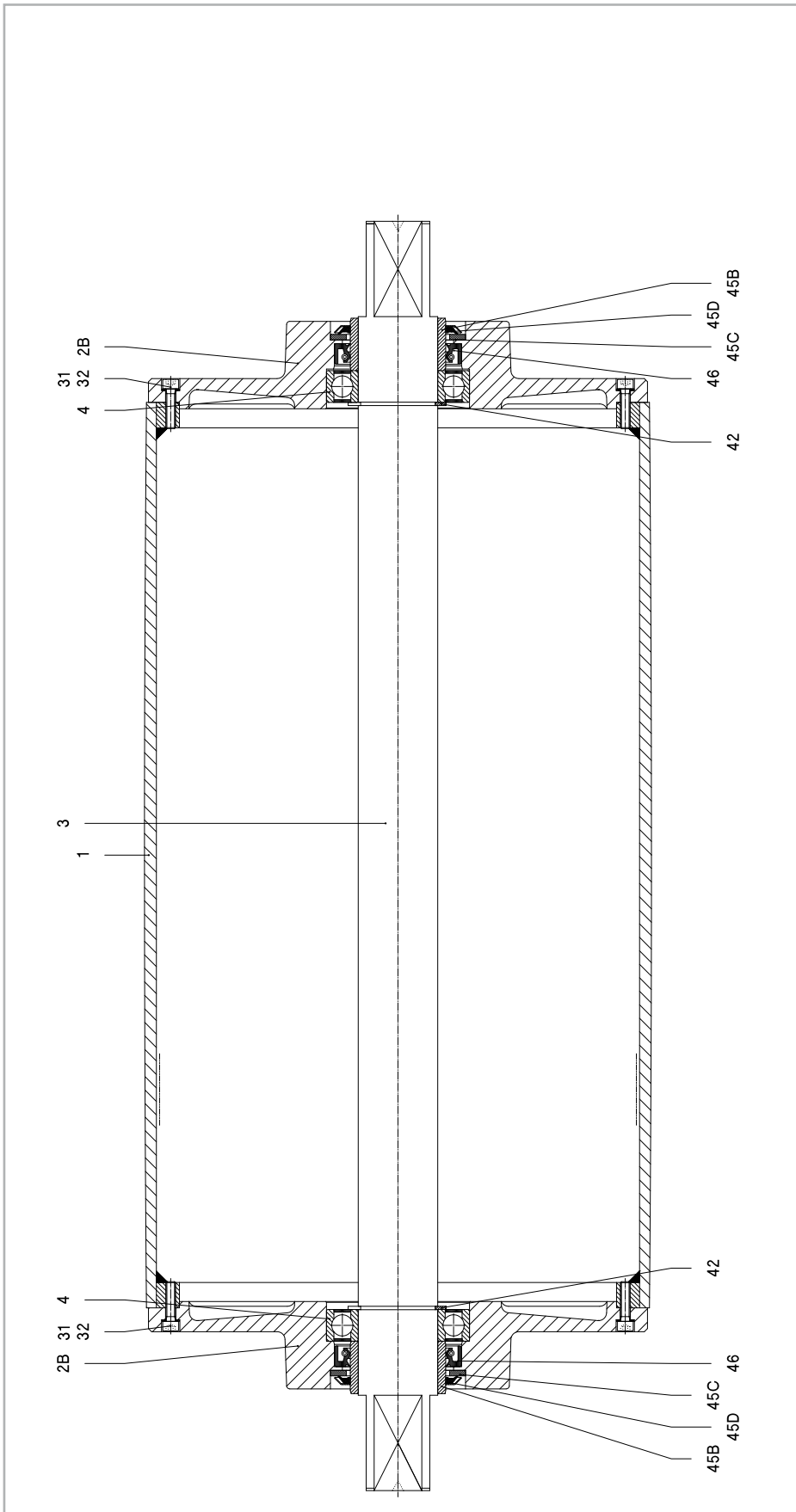

Remark: Taildrum also available in B-design (KT315B50)

1	Shell	42	Circlip
2B	Endflange	45B	Bearing race
3	Shaft	45C	Shim plated
4	Ballbearing	45D	Gammaring
31	Int. hex screw	46	Oliseal
32	Washer		

Material

The external parts of the Drummotor are made from mild steel and cast iron. Depending on the application it is also possible to manufacture in stainless steel (complete or part). You can choose between stainless steel 304 (general food industry) and stainless steel 316 (salt water applications).

Backstop - Brake

If an inclined belt conveyor is stopped fully loaded, it could run backwards.

To prevent this we can install a backstop. One of the bearings in the Drummotor is replaced by a one way bearing. The way this bearing is installed determines the direction of rotation of the drum. TBRH indicates a cw rotation and TBLH ccw.

In situations where a Drummotor needs to be able to drive in both directions it is not possible to use a backstop. In this case we use a brake. When an declined belt or a horizontal belt needs to be stopped quickly to pick or place items a brake is the best solution.

Inclined position

Sometimes a Drummotor needs to be installed on an inclined or even vertical position. This is possible, but we need to make adjustments to the oil level in the drum as the oil will flow to the lower side of the Drummotor causing the top bearing to run without lubrication. To prevent problems we will need to know the installation angle so we can fill the drum with extra oil and fit a double sealed bearing on the upper side.

Thermal protection

A Van der Graaf Drummotor can be fitted with thermal protection. This consists of either a thermistor (PTC) or bi-metal (klixon). We install these on each phase of the electric motor.

Encoder - Sensor bearing

In certain applications it is required to measure the speed or position of a conveyor belt. For this type of application we can install an encoder or sensor bearing to accurately measure rotational speed of the Drummotor.

The accuracy needed will determine the type of encoder or sensor used.

Lagging

The power produced by the Drummotor has to be transferred to the belt and lagging is used to give more friction between the Drummotor and the conveyor belt. Van der Graaf can fit your Drummotor with different kinds of lagging.

There is a difference between cold and hot vulcanised lagging. Cold vulcanised means the lagging is glued to the Drummotor usually in sheet form and the join 'welded' together. Hot vulcanising is a process where the shell is wrapped around with thin layers of rubber. The shell with the rubber is then baked in an autoclave fusing the layers together creating a seamless finish.

It is possible to cut grooves (e.g chevron or diamond) in the lagging.

Sprockets

Do you wish to use a Drummotor to drive modular belts? Van der Graaf can help you! Fitting sprockets suitable for various types of modular belts is a simple solution. The Drummotor is manufactured with a cylindrical shell and machined with a patented 'keying' system. The sprockets are simply 'slid' on and locked securely into position.

Sealings for mild steel Drummotors

RB sealing - IP 66



This is Van der Graaf's standard sealing. This type of sealing will work in most conditions.

RBS sealing - IP 66



This sealing is specifically designed for those applications where high water pressure is used for cleaning.

HD sealing - IP 66



This sealing is designed for abrasive applications, like sand, gravel and soil.

Sealings for stainless steel Drummotors

CR sealing - IP 66



This is our standard sealing for stainless steel Drummotors, a very effective, multi labyrinth sealing.

UW sealing - IP 68



This sealing is suitable for under water applications. The maximum depth is approx 2,5 m.

Options

Specification	Standard	Optional
Construction		
Shafts and bolts	Mild steel	Stainless steel
End caps	Cast iron	Stainless steel
Shell	Mild steel	Stainless steel
Junctionbox	Cast iron	PU coated cast iron or stainless steel
Cable		Shielded or non-shielded
Sealing mild steel	RB	RBS, HD
Sealing stainless steel	CR	UW
Shell		
Crowned	•	
Cylindrical		•
Balanced		•
Lagging, cold vulcanised		•
Lagging, hot vulcanised		•
Lagging, FDA approved		•
Fitted with grooves, patterns		•
Electro motor		
Three-phase asynchronous	•	
Power supply (P < 3 kW)	230/400 V - 50 Hz	Other voltages and frequencies on request
Power supply (P ≥ 3 kW)	400/690 V - 50 Hz	Other voltages and frequencies on request
Two speed (Dahlander)		•
Insulation class	F	H
Thermal protection		Bi-metal or thermistor
Run by frequency inverter	•	
Other options		
Food grade oil		•
Backstop, mechanical		•
Brake, electro mechanical		•
Clutch brake, electro mechanical		•
Inclined or vertical position		•
Other facewidth's		•
Different shaft designs		•
Encoder or sensor bearing in Drummotor		•
Encoder or sensor bearing in Taildrum		•
Certificates		
CE	•	
UL		•
CSA		•
ATEX zone 22, dust		•



Product range

Our products, an overview

Drum motor type	TM 100B25	TM 113B25	TM 127.25	TM 138.25	TM 160.25	TM 160.30	TM 215.30	TM 215.40
Drum diameter (mm)	100	113	127	138	160	160	215	215
Shaft diameter (mm)	25	25	25	25	25	30	30	40
Power (kW)	0.05-0.37	0.04-0.55	0.10-1.1	0.10-1.1	0.10-0.75	0.10-2.2	0.10-2.2	0.37-5.5
Speed (m/s)	0.007-3.60	0.008-4.40	0.008-2.60	0.009-2.80	0.13-3.30	0.06-4.00	0.08-5.30	0.12-4.70

Drum motor type	TM 215B50	TM 273.40	TM 315.40	TM 315.50	TM 400A50	TM 400.60	TM 500A60	TM 500A75
Drum diameter (mm)	215	273	315	315	400	400	500	500
Shaft diameter (mm)	50	40	40	50	50	60	60	75
Power (kW)	1.5-4.0	0.37-5.5	0.37-5.5	1.1-11	1.1-11	1.5-22	1.5-22	11-30
Speed (m/s)	0.18-0.31	0.17-5.00	0.18-5.20	0.16-4.40	0.20-4.80	0.20-4.60	0.25-4.70	0.80-3.20

Drum motor type	TM 620A75	TM 630A100	TM 800A100	TM 800A130
Drum diameter (mm)	620	630	800	800
Shaft diameter (mm)	75	100	100	130
Power (kW)	11-30	22-55	22-55	55-132
Speed (m/s)	1.00-3.90	1.00-4.00	1.25-5.10	1.60-4.50

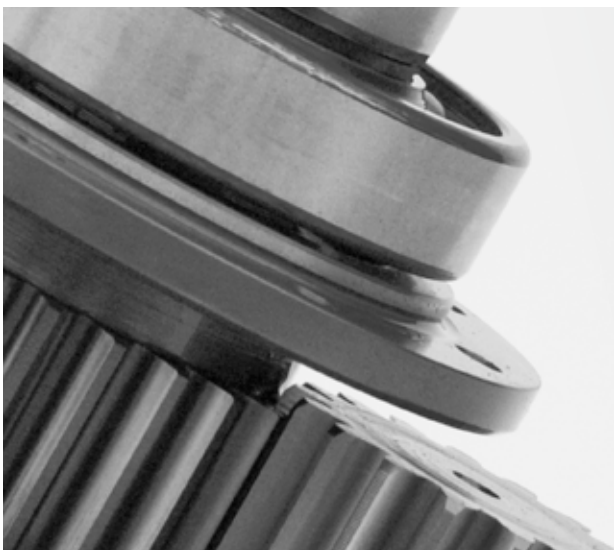

Design benefits

- Robust, industrial design
- Fully enclosed
- Oil filled
- Well-sized gears and bearings

Installation advantages

- Easy to install
- Compact and reliable
- Easy to clean
- Virtually maintenance free
- Low Life Cycle Costs





Van der Graaf

Power Transmission Equipment

Contact us

Netherlands

Van der Graaf B.V.
De Weijert 14
P.O. Box 3
8325 ZG Vollenhove
Tel: 00 31 527 241441
Fax: 00 31 527 241488
E-mail: info@vandergraafpte.nl
www.vandergraafpte.nl



Canada

Van der Graaf Inc.
2 Van der Graaf Court
Brampton
Ontario L6T 5R6
Tel: 00 1 905 793 8100
Fax: 00 1 905 793 812
E-mail: info@vandergraaf.com
www.vandergraaf.com



Great Britain

Van der Graaf U.K. Ltd.
Unit 23, The Metro Centre
Welbeck Way Woodston
Peterborough PE2 7UH
Tel: 00 44 1733 391777
Fax: 00 44 1733 391044
E-mail: sales@vandergraaf.co.uk
www.drummy.com



USA

Van der Graaf Corp.
51515 Celeste
Shelby Township
48315 Michigan
Tel: 00 1 866 595 3292
Fax: 00 1 888 326 0089



Germany

Van der Graaf GmbH
Rheiner Straße 24 B
48432 Rheine-Mesum
Tel: 00 49 5975 306210
Fax: 00 49 5975 3062120
E-mail: info@vandergraaf.de
www.vandergraaf.de



Sweden

Van der Graaf Scandinavia AB
Spinngatan 2
267 73 Billesholm
Tel: 00 46 42 22 0802
Fax: 00 46 42 22 0803
E-mail: info@vandergraaf.se
www.vandergraaf.se



Finland

Van der Graaf Scandinavia AB
Tel: 00 358 400 419063
E-mail: info@vandergraaf.fi
www.vandergraaf.fi