

Product information

Drummotors

**TM 215B50**



*Van der Graaf*  
Power Transmission Equipment

[www.vandergraafpte.nl](http://www.vandergraafpte.nl)



The TM 215B50's





playground



# TM 215B50

## A wide range of applications

Van der Graaf has achieved a prominent position on both the domestic and international market with its "GV" Drummotors.

The "GV" Drummotor has found success in a wide range of applications including the following: automotive, X-ray, construction, postal, courier, mining, aggregate, airline baggage, package flow, tyre manufacturing, fish processing, poultry processing, meat processing, agriculture, fruit and vegetable, farming, forestry, baking, dairy and many more.

4	Introduction
5	Selection table
6	Selection table Dahlander motors
7	Dimensions Drummotor mild steel
	Dimensions Taildrum mild steel
8	Dimensions bracket
9	Cable exit
10	Cross sectional / parts description
12	Options
15	Product range
16	Contact us



## Selection table

TYPE TM 215B50	Power kW	Beltspeed m/s at 50 Hz		Min. L mm Design B	Full load curr. 400 V - 50 Hz I = ... A	Weight kg L=500
		0,31 11870	0,28 13140			
<b>455 PL2</b>	<b>4,00</b>	<b>0,31</b> 11870	<b>0,28</b> 13140	600	8,8	117
<b>440 PL2</b>	<b>3,00</b>	<b>0,31</b> 8900	<b>0,28</b> 9855	600	6,6	117
<b>630 PL2</b>	<b>2,20</b>	<b>0,20</b> 10120	<b>0,18</b> 11240	600	5,5	117
<b>620 PL2</b>	<b>1,50</b>	<b>0,20</b> 6900	<b>0,18</b> 7665	600	3,7	117

Available standard facewidth's: 600 - 650 - 700 - 750 - 800 - 850 - 900 - 950 - 1000 mm

When an electro-mechanical brake is fitted, the minimum facewidth is increased by 100 mm

The total weight of a Drummotor grows approx. 5 kg per 100 mm

Available torque: (Beltpull N x drum diameter m) / 2 Nm

## Selection table Dahlander motors

TYPE TM 215B50	Power kW	Beltspeed m/s at 50 Hz		Min. L mm Design B	Full load curr. 400 V - 50 Hz I = ... A	Weight kg L=600
		Beltpull N				
<b>430/240 PL2</b>	<b>2,20/3,00</b>	<b>0,31/0,62</b> 6530/4450	<b>0,28/0,56</b> 7230/4930	600	5,0/6,9	117
<b>816/430 PL2</b>	<b>1,20/2,20</b>	<b>0,15/0,30</b> 7360/6745	<b>0,14/0,28</b> 7885/7230	600	3,8/4,3	117
<b>810/420 PL2</b>	<b>0,75/1,50</b>	<b>0,15/0,30</b> 4600	<b>0,14/0,28</b> 4930	600	3,3/4,6	117

Available standard facewidth's: 600 - 650 - 700 - 750 - 800 - 850 - 900 - 950 - 1000 mm

When an electro-mechanical brake is fitted, the minimum facewidth is increased by 100 mm

The total weight of a Drummotor grows approx. 5 kg per 100 mm

Available torque: (Beltpull N x drum diameter m) / 2 Nm



# Dimensions

## TM 215B50

TM 215B50, mild steel Drummotor with cast iron junctionbox

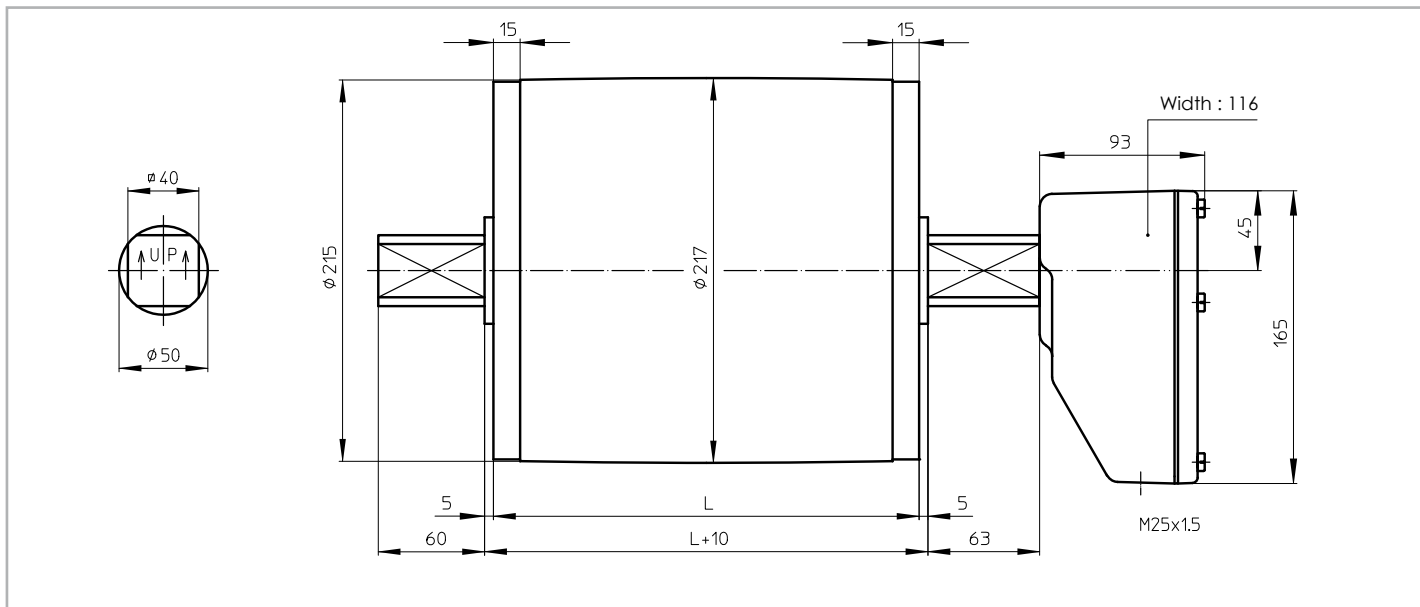

## KT 215B50

KT 215B50, mild steel Taildrum

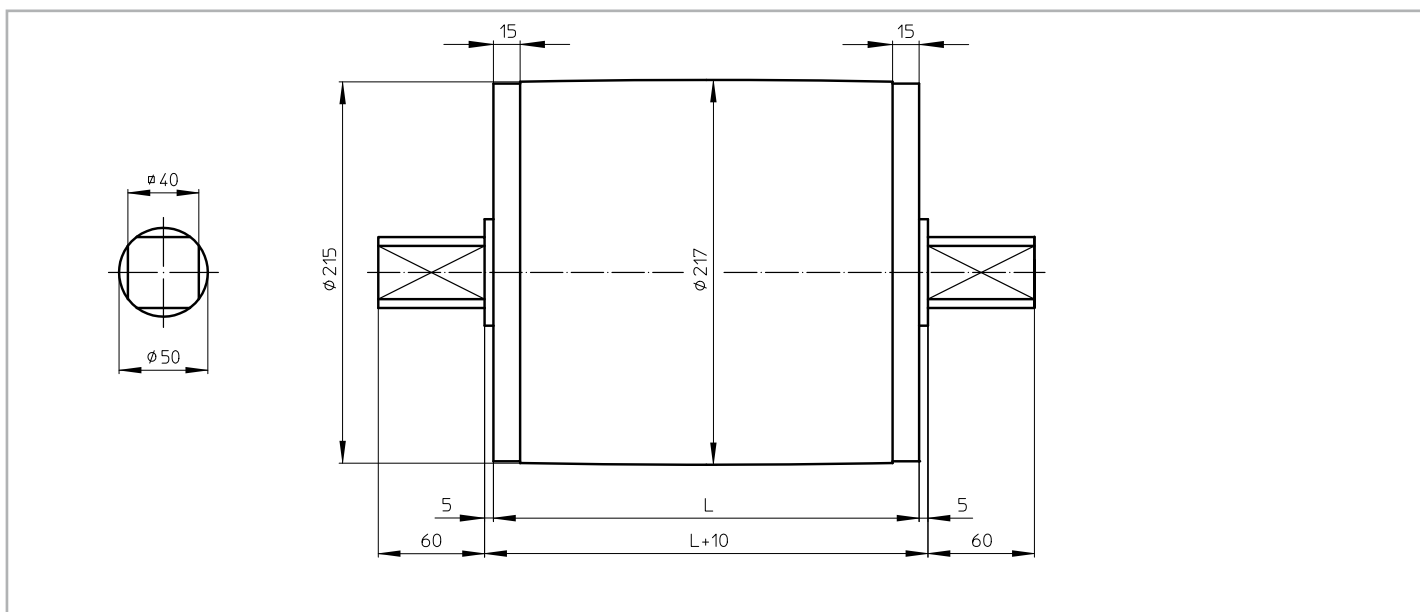

## Dimensions bracket

### AB 50

AB 50, cast iron or stainless steel bracket

Weight: 7,2 kg per pair

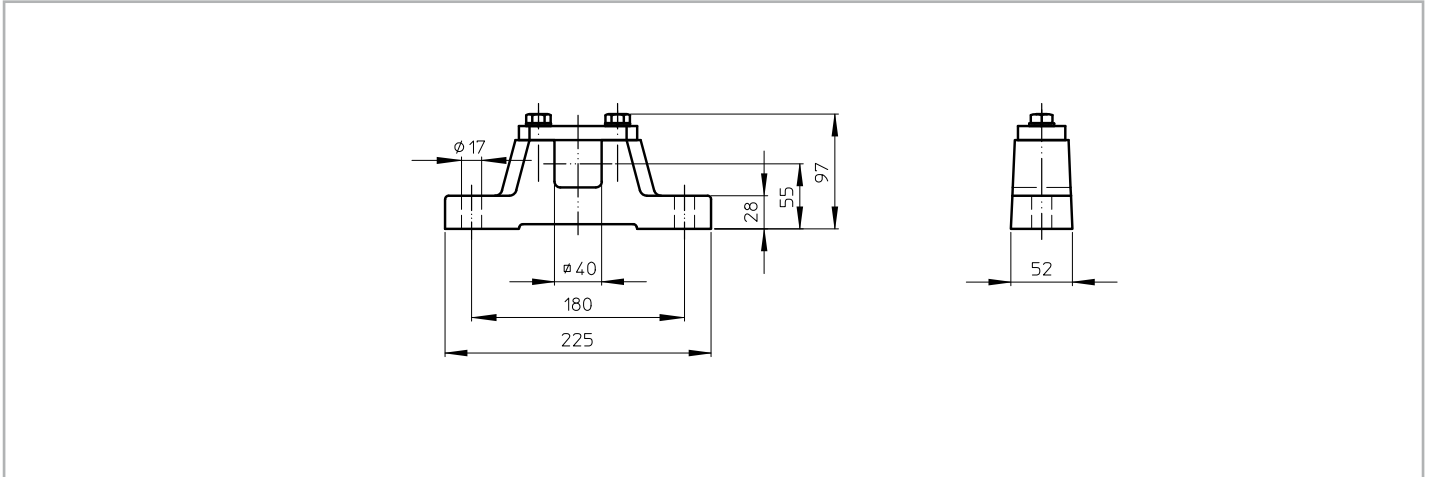





## Cable exit

Standard design of a TM 215B50 is with a cast iron junctionbox. For stainless steel design, this can be either a polyamide or stainless steel junctionbox.

On request a Drummotor can be fitted with a cable. In this case it is important to know the available voltage (preferably 1 voltage), the length of the cable, whether the cable is shielded or not and the type of cable exit. An overview of available cable exits is shown below.

### Option 1

Straight cable exit with cable gland

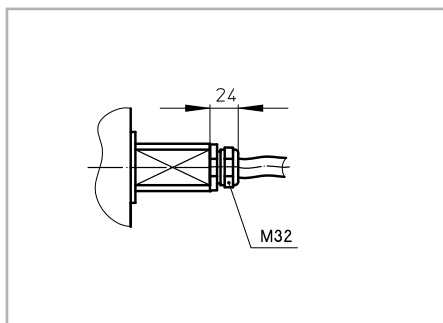

### Option 3

Elbow cable exit with cable gland  
(minimum facewidth increases with 50 mm)

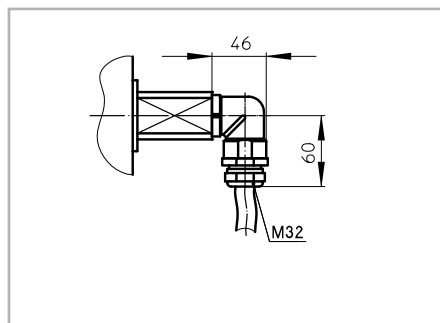

# Cross sectional / parts description

TM 215B50 PL2

Legenda

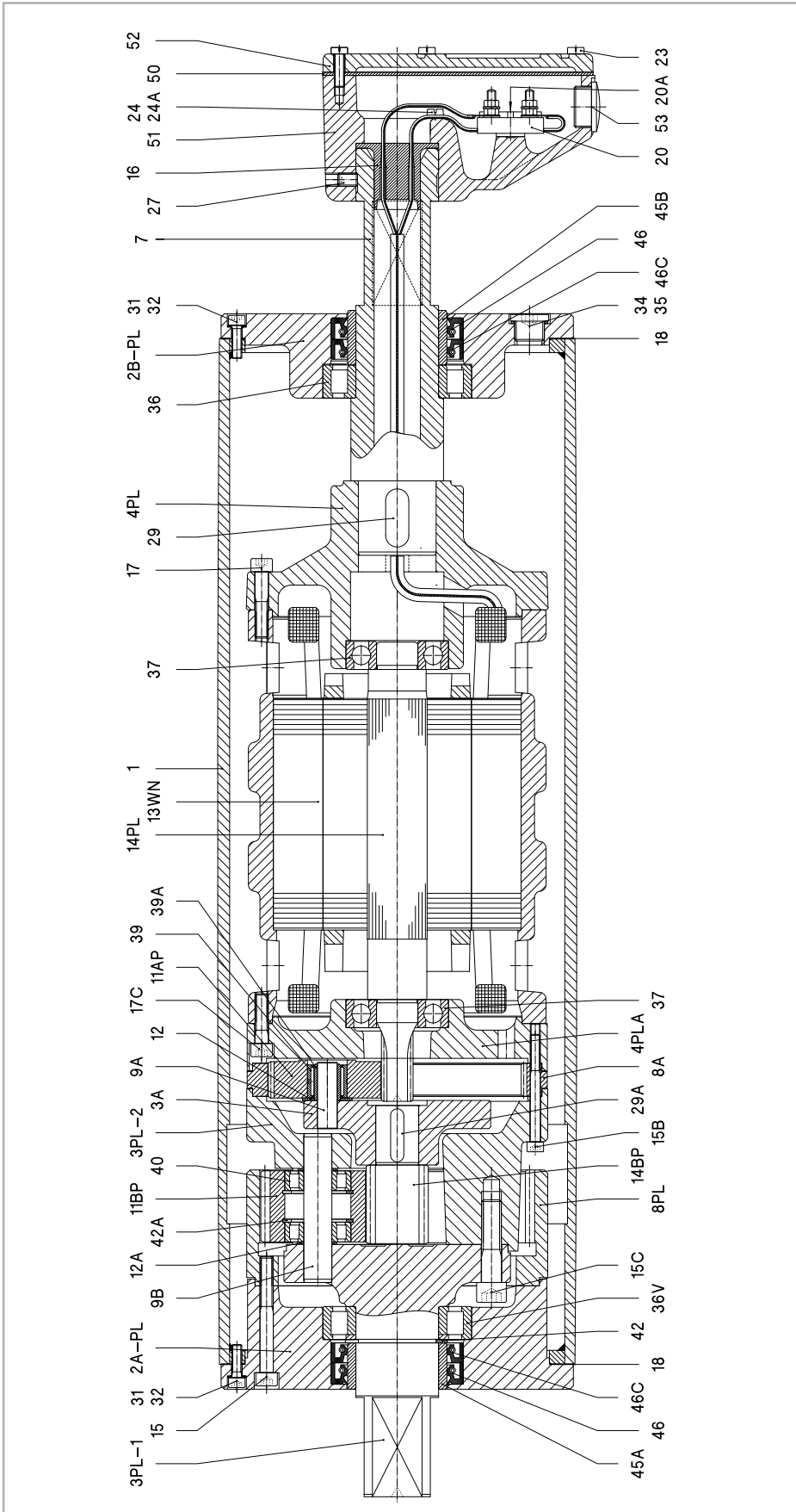

1	Shell	9B	Cylindrical pin	17	Int. hex screw	34	Fillerplug	46	Oilseal
2A-PL	Endflange	11AP	Planetary gear	17C	Int. hex screw	35	Washer	46C	Oilseal
2B-PL	Endflange	11BP	Planetary gear	18	Gasket	36	Cyl. roller bearing	50	Seal
3A	Planetary carrier	12	Shim	20	Terminalboard	36V	Cyl. roller bearing	51	Junctionbox
3PL-1	Connection shaft	12A	Shim	23	Cyl. head screw	37	Ballbearing	52	Junctionbox cover
3PL-2	Planetary housing	13WN	Stator	24	Cyl. head screw	39	Needlebearing	53	Stopping plug
4PL	Motoflange	14PL	Rotor	24A	Toothed lock washer	39A	Innerring	57	Dataplate
4PLA	Motoflange	14BP	Sunwheel	27	Setscrew	40	Cyl. roller bearing		
7	Hollow shaft	15	Int. hex screw	29	Key	42	Circlip		
8A	Internal gear	15B	Int. hex screw	29A	Key	42A	Circlip		
8PL	Internal gear	15C	Int. hex screw	31	Int. hex screw	45A	Bearing race		
9A	Cylindrical pin	16	Cable passage	32	Washer	45B	Bearing race		



# Cross sectional / parts description

KT 215B50

Legenda

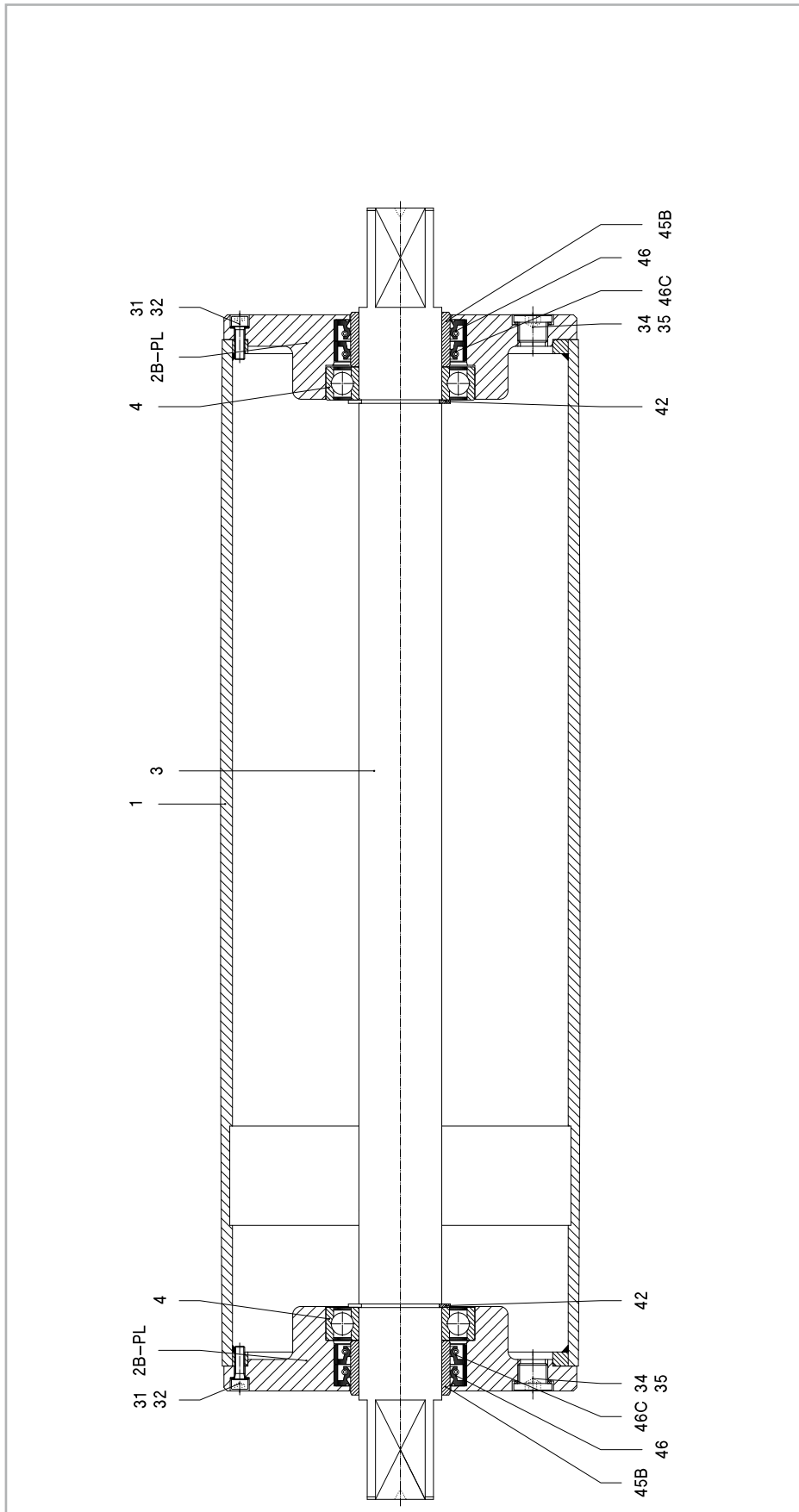

- |       |                |     |              |
|-------|----------------|-----|--------------|
| 1     | Shell          | 34  | Fillerplug   |
| 2B-PL | Endflange      | 35  | Washer       |
| 3     | Shaft          | 42  | Circlip      |
| 4     | Ballbearing    | 45B | Bearing race |
| 31    | Int. hex screw | 46  | Olised       |
| 32    | Washer         | 46C | Olised       |

## Material

The external parts of the Drummotor are made from mild steel and cast iron. Depending on the application it is also possible to manufacture in stainless steel (complete or part). You can choose between stainless steel 304 (general food industry) and stainless steel 316 (salt water applications).

## Backstop - Brake

If an inclined belt conveyor is stopped fully loaded, it could run backwards.

To prevent this we can install a backstop. One of the bearings in the Drummotor is replaced by a one way bearing. The way this bearing is installed determines the direction of rotation of the drum. TBRH indicates a cw rotation and TBLH ccw.

In situations where a Drummotor needs to be able to drive in both directions it is not possible to use a backstop. In this case we use a brake. When an declined belt or a horizontal belt needs to be stopped quickly to pick or place items a brake is the best solution.

## Inclined position

Sometimes a Drummotor needs to be installed on an inclined or even vertical position. This is possible, but we need to make adjustments to the oil level in the drum as the oil will flow to the lower side of the Drummotor causing the top bearing to run without lubrication. To prevent problems we will need to know the installation angle so we can fill the drum with extra oil and fit a double sealed bearing on the upper side.

## Thermal protection

A Van der Graaf Drummotor can be fitted with thermal protection. This consists of either a thermistor (PTC) or bi-metal (klixon). We install these on each phase of the electric motor.

## Encoder - Sensor bearing

In certain applications it is required to measure the speed or position of a conveyor belt. For this type of application we can install an encoder or sensor bearing to accurately measure rotational speed of the Drummotor.

The accuracy needed will determine the type of encoder or sensor used.

## Lagging

The power produced by the Drummotor has to be transferred to the belt and lagging is used to give more friction between the Drummotor and the conveyor belt. Van der Graaf can fit your Drummotor with different kinds of lagging.

There is a difference between cold and hot vulcanised lagging. Cold vulcanised means the lagging is glued to the Drummotor usually in sheet form and the join 'welded' together. Hot vulcanising is a process where the shell is wrapped around with thin layers of rubber. The shell with the rubber is then baked in an autoclave fusing the layers together creating a seamless finish.

It is possible to cut grooves (e.g chevron or diamond) in the lagging.

## Sprockets

Do you wish to use a Drummotor to drive modular belts? Van der Graaf can help you! Fitting sprockets suitable for various types of modular belts is a simple solution. The Drummotor is manufactured with a cylindrical shell and machined with a patented 'keying' system. The sprockets are simply 'slid' on and locked securely into position.





## Options

### Sealings for mild steel Drummotors

RBS sealing - IP 66



This sealing is specifically designed for those applications where high water pressure is used for cleaning.

HD sealing - IP 66



This sealing is designed for abrasive applications, like sand, gravel and soil.

### Sealings for stainless steel Drummotors

CR sealing - IP 66



This is our standard sealing for stainless steel Drummotors, a very effective, multi labyrinth sealing.

# Options

Specification	Standard	Optional
<b>Construction</b>		
Shafts and bolts	Mild steel	Stainless steel
Endflanges	Cast iron	Stainless steel
Shell	Mild steel	Stainless steel
Junctionbox	Cast iron	PU coated cast iron or stainless steel
Cable		Shielded or non-shielded
Sealing mild steel		RBS, HD
Sealing stainless steel	CR	
<b>Shell</b>		
Crowned	•	
Cylindrical		•
Balanced		•
Lagging, cold vulcanised		•
Lagging, hot vulcanised		•
Lagging, FDA approved		•
Fitted with grooves, patterns		•
Sprockets		•
<b>Electro motor</b>		
Three-phase asynchronous	•	
Power supply ( $P \leq 3$ kW)	230/400 V - 50 Hz	Other voltages and frequencies on request
Power supply ( $P > 3$ kW)	400/690 V - 50 Hz	Other voltages and frequencies on request
Two speed (Dahlander)		•
Insulation class	F	H
Thermal protection		Bi-metal or thermistor
Run by frequency inverter	•	
<b>Other options</b>		
Food grade oil		•
Backstop, mechanical		•
Brake, electro mechanical		•
Inclined or vertical position		•
Other facewidth's		•
Different shaft designs		•
Encoder or sensor bearing in Drummotor		•
Encoder or sensor bearing in Taildrum		•
<b>Certificates</b>		
CE	•	
UL		•
CSA		•
ATEX zone 22, dust		•



## Product range

### Our products, an overview

Drum motor type	TM 100B25	TM 113B25	TM 127.25	TM 138.25	TM 160.25	TM 160.30	TM 215.30	TM 215.40
Drum diameter (mm)	100	113	127	138	160	160	215	215
Shaft diameter (mm)	25	25	25	25	25	30	30	40
Power (kW)	0.05-0.37	0.04-0.55	0.10-1.1	0.10-1.1	0.10-0.75	0.10-2.2	0.10-2.2	0.37-5.5
Speed (m/s)	0.007-3.60	0.008-4.40	0.008-2.60	0.009-2.80	0.13-3.30	0.06-4.00	0.08-5.30	0.12-4.70

Drum motor type	TM 215B50	TM 273.40	TM 315.40	TM 315.50	TM 400A50	TM 400.60	TM 500A60	TM 500A75
Drum diameter (mm)	215	273	315	315	400	400	500	500
Shaft diameter (mm)	50	40	40	50	50	60	60	75
Power (kW)	1.5-4.0	0.37-5.5	0.37-5.5	1.1-11	1.1-11	1.5-22	1.5-22	11-30
Speed (m/s)	0.18-0.31	0.17-5.00	0.18-5.20	0.16-4.40	0.20-4.80	0.20-4.60	0.25-4.70	0.80-3.20

Drum motor type	TM 620A75	TM 630A100	TM 800A100	TM 800A130
Drum diameter (mm)	620	630	800	800
Shaft diameter (mm)	75	100	100	130
Power (kW)	11-30	22-55	22-55	55-132
Speed (m/s)	1.00-3.90	1.00-4.00	1.25-5.10	1.60-4.50

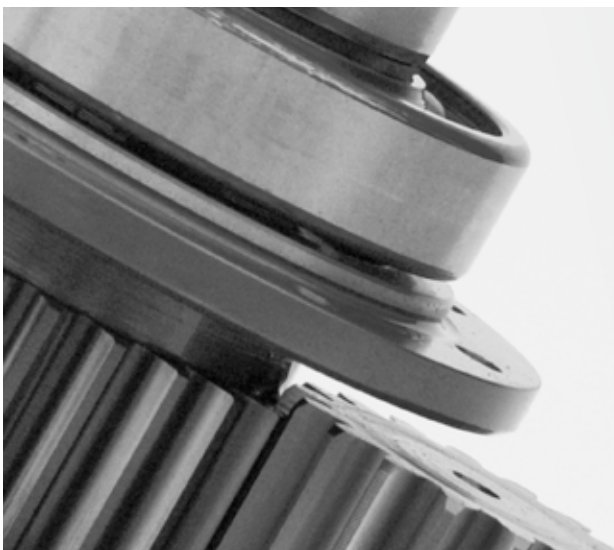

#### Design benefits

- Robust, industrial design
- Fully enclosed
- Oil filled
- Well-sized gears and bearings

#### Installation advantages

- Easy to install
- Compact and reliable
- Easy to clean
- Virtually maintenance free
- Low Life Cycle Costs





# Van der Graaf

## Power Transmission Equipment

### Contact us

#### Netherlands

Van der Graaf B.V.  
De Weijert 14  
P.O. Box 3  
8325 ZG Vollenhove  
Tel: 00 31 527 241441  
Fax: 00 31 527 241488  
E-mail: [info@vandergraafpte.nl](mailto:info@vandergraafpte.nl)  
[www.vandergraafpte.nl](http://www.vandergraafpte.nl)



#### Canada

Van der Graaf Inc.  
2 Van der Graaf Court  
Brampton  
Ontario L6T 5R6  
Tel: 00 1 905 793 8100  
Fax: 00 1 905 793 812  
E-mail: [info@vandergraaf.com](mailto:info@vandergraaf.com)  
[www.vandergraaf.com](http://www.vandergraaf.com)



#### Great Britain

Van der Graaf U.K. Ltd.  
Unit 23, The Metro Centre  
Welbeck Way Woodston  
Peterborough PE2 7UH  
Tel: 00 44 1733 391777  
Fax: 00 44 1733 391044  
E-mail: [sales@vandergraaf.co.uk](mailto:sales@vandergraaf.co.uk)  
[www.drummotor.com](http://www.drummotor.com)



#### USA

Van der Graaf Corp.  
51515 Celeste  
Shelby Township  
48315 Michigan  
Tel: 00 1 866 595 3292  
Fax: 00 1 888 326 0089



#### Germany

Van der Graaf GmbH  
Rheiner Straße 24 B  
48432 Rheine-Mesum  
Tel: 00 49 5975 306210  
Fax: 00 49 5975 3062120  
E-mail: [info@vandergraaf.de](mailto:info@vandergraaf.de)  
[www.vandergraaf.de](http://www.vandergraaf.de)



#### Sweden

Van der Graaf Scandinavia AB  
Spinngatan 2  
267 73 Billesholm  
Tel: 00 46 42 22 0802  
Fax: 00 46 42 22 0803  
E-mail: [info@vandergraaf.se](mailto:info@vandergraaf.se)  
[www.vandergraaf.se](http://www.vandergraaf.se)



#### Finland

Van der Graaf Scandinavia AB  
Tel: 00 358 400 419063  
E-mail: [info@vandergraaf.fi](mailto:info@vandergraaf.fi)  
[www.vandergraaf.fi](http://www.vandergraaf.fi)